

273/2  
GEOGRAPHY  
PAPER 2  
AUGUST 2005  
2 HOURS 30 MINUTES

## **MASAKA DIOCESE JOINT MOCK EXAMINATIONS 2005**

**GEOGRAPHY**

**PAPER 2**

**2 HOURS 30 MINUTES**

### **INSTRUCTIONS TO CANDIDATES:**

- Answer **four** questions in all.
- Choose **two** questions from **Part I** and two from **Part II**.
- In **Part II**, not more than **one** question may be answered from **one** area.

## PART I: THE REST OF AFRICA

1. Study the map of Africa showing the Highlands and answer the questions that follow.

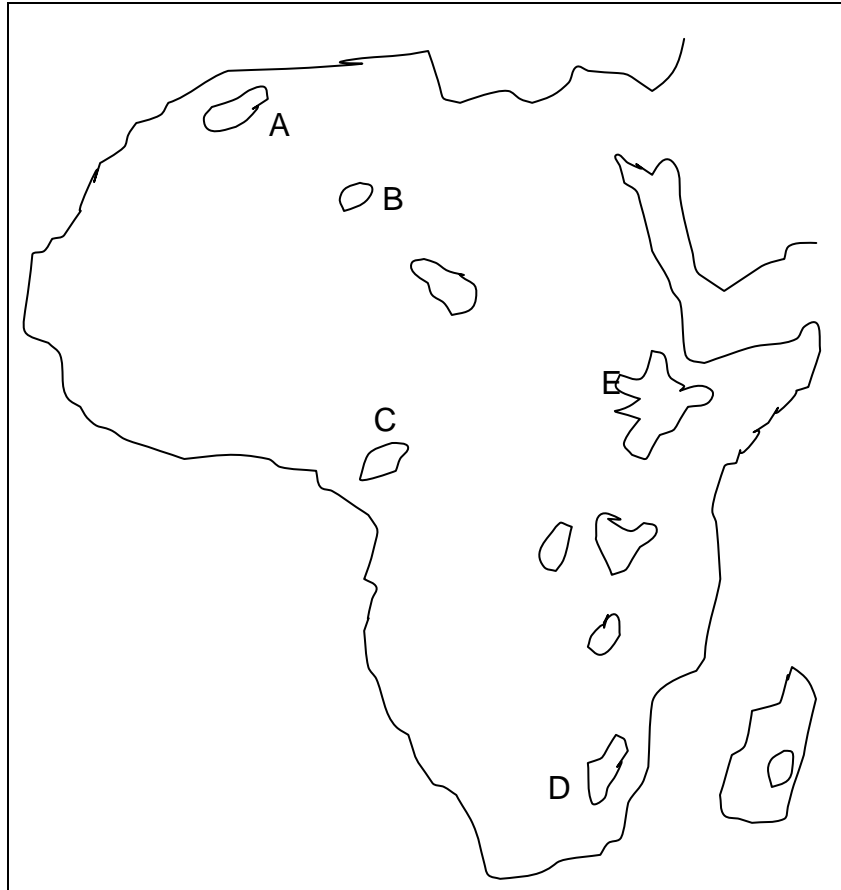







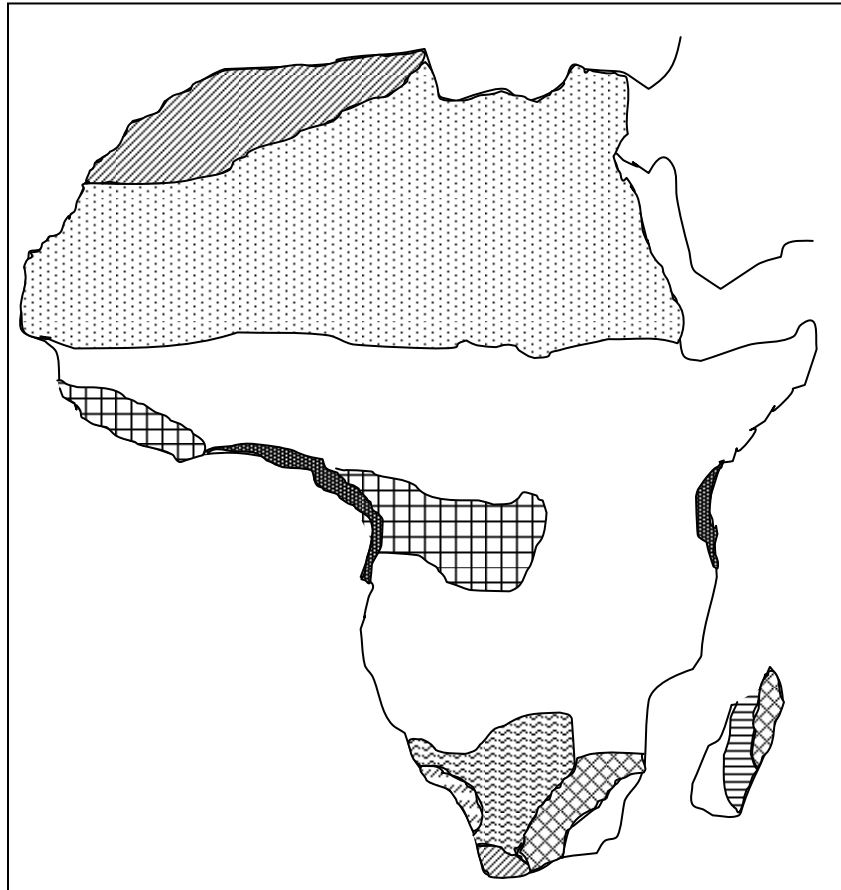

- (a) (i) Name the highlands marked A, B, C and D.
- (ii) Choosing any one highland marked A – E with the help of diagrams explain how it was formed.
- (b) (i) What economic activities take place at the highlands marked E?
- (ii) Describe the physical processes that have favoured the economic activities names in (b) (i) above.
- (c) (i) State the problems faced by farmers in the Ethiopian highlands.

(ii) How are the problems stated in (c) (i) being solved?

2. The map below shows the distribution of natural vegetation of Africa. Use it to answer the questions which follow.



KEY

	.....
	.....
	.....
	.....
	.....
	.....
	.....
	.....
	.....

(a) Complete the key by naming the vegetation types.

- (b) (i) Mention three factors which have influenced the distribution of tropical rain forests in Africa.
- (ii) What are the characteristics of tropical rain forests?
- (c) Imagine you were a new settler in Zaire (Congo) basin; explain how you would develop the area.
- (d) Give **five** reasons why forests should be conserved in Africa.
- (e) What problems are likely to be faced in conserving forests?

3. Study the table below showing the climate of station X located near the coast of West Africa and answer the questions that follow.

Month	J	F	M	A	M	J	J	A	S	O	N	D
Temp. °C	4.4	6.1	10.0	16.7	21.7	26.7	29.4	29.4	25.0	19.4	12.8	7.2
RF (mm)	48	48	97	152	165	244	180	97	71	81	48	28

- (a) Draw a suitable graph to show the climate of station X
- (b) Calculate the:
  - (i) Annual temperature range.
  - (ii) Total annual rainfall.
- (c) Describe the characteristics of the climate for station X.
- (d) Explain the influence of the climate on the agricultural activities in the area.

#### 4. TABLE SHOWING GOLD PRODUCTION IN TONNES

Country	1973	1975	% change
South Africa	855.6	788.5	- 11.34
Ghana	22.7	21.4	.....
Zimbabwe	15.5	18.6	.....
D.R.C.	4.2	4.4	4.76
World total	1,138.0	1.454.0	.....

Study the table and answer the questions which follow.

- (a) (i) Calculate the percentage change in gold production for Ghana and Zimbabwe.
- (ii) Which country had the greatest increase in gold production between 1973 and 1975?
- (iii) What percentage of the total world production came from the Africa countries?
- (b) With reference to Ghana,
- (i) Name **two** mining towns.
- (ii) Briefly describe the methods used in mining gold there.
- (iii) What factors have favoured the development of mining in that country?
- (c) Name **two** other minerals mined in Ghana.
- (d) (i) Mention **four** ways in which the mining industry has contributed to the development of Ghana.
- (ii) State **four** problems associated with mining in towns.
- (iii) Suggest ways in which some of these problems can be overcome.

5.

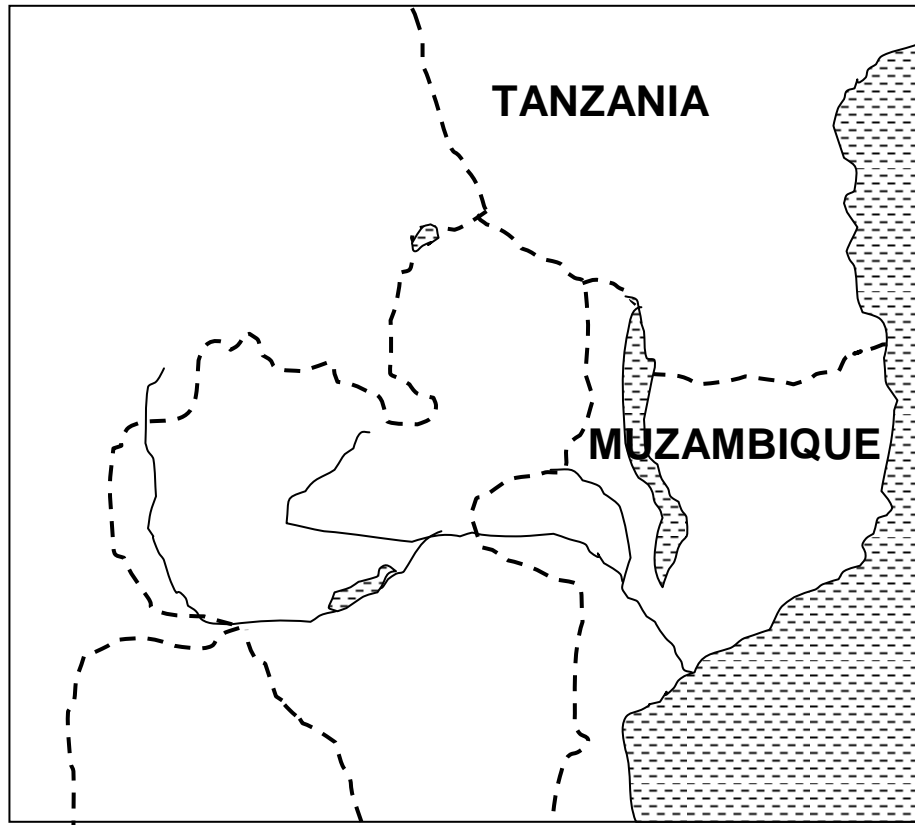

- (a) On the sketch map provided mark and name;
- (i) The Tazara railway line.
  - (ii) Two countries outside East Africa served by this line.
  - (iii) Three important towns along the line.
- (b) (i) What ways has the Tazara railway benefited the region?
- (ii) What problems have resulted from the use of Tazara railway?
- (c) Name the other routes through which the region can transport its commodities.

6. (a) Draw a sketch map of Egypt and on it mark and name:
- (i) The White Nile.
  - (ii) The towns: Cairo and Alexandria.
  - (iii) The Aswan High Dam and Lake Nasser.
- (b) (i) Part from chemical industries, name two other industries that have developed in Egypt.
- (ii) State the raw materials used in the industries named in (b) (i) above.
- (c) (i) Explain why chemical industries have developed in Egypt.
- (ii) Name any **two** products obtained from chemical industries in Egypt.
- (d) (i) Mention any **four** problems hindering effective industrialization in Egypt.
- (ii) Name **three** towns in East Africa where chemical industries have been developed.

**PART II: STUDIES OF DEVELOPMENT REGION I: NORTH AMERICA.**

7. (a) (i) Name the provinces which make up the Prairies of Canada.
- (ii) Mention **three** types of farming practiced in the Canadian Prairies.
- (iii) What is monoculture?
- (b) What are the conditions which have favoured wheat growing in Canada?
- (c) (i) State the problems of wheat growing and marketing in Canada.
- (ii) What are the solutions to the problems stated in (c) (i) above.

8.

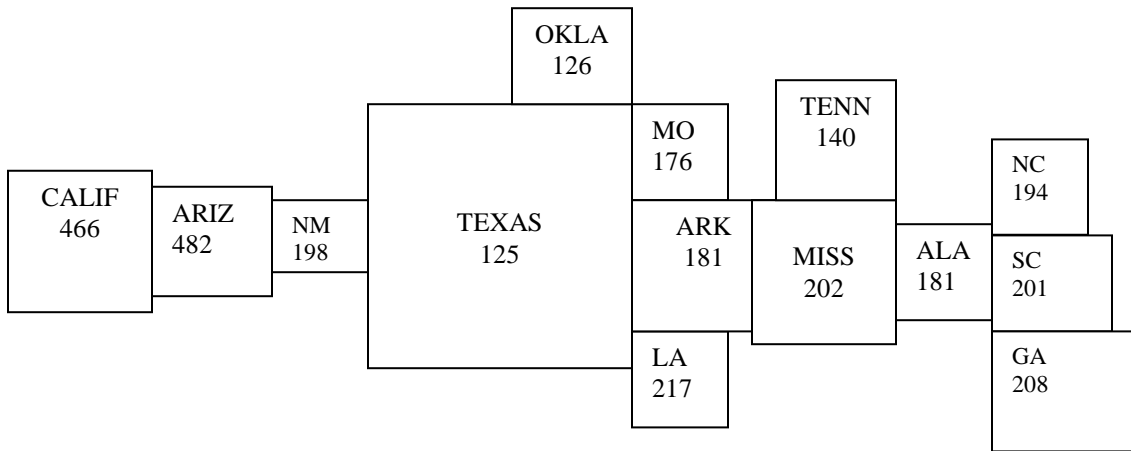

KEY:

CALIF =	California	MISS =	Mississippi
ARIZ =	Arizona	TENN =	Tennessee
NM =	New Mexico	ALA =	Alabama
OKLA =	Oklahoma	NC =	North Carolina
MO =	Missouri	SC =	South Carolina
ARK =	Arkansas	GA =	Georgia
LA =	Lousiana		

The figure above shows cotton production in the southern states of U.S.A. Each square represents a cotton-growing state, and the area of the square is proportional to the area under cotton, while the figure in the square represents the yield in kilograms per acre for the state.

Study the figure and answer the following questions.

- (a) (i) Name the **four** leading cotton producing states.
- (ii) Name **four** states with the lowest cotton yields.

- (b) (i) Give **two** reasons which favoured cotton growing in the Southern States of America.
  - (ii) Mention the factors which favour high cotton yields in California.
  - (c) Explain why cotton production in the South-East has become relatively less important.
  - (d) Briefly mention the steps taken to improve the social and economic conditions of the people living in the cotton growing areas.
- 9.
- (a) (i) List **five** of the states in new England.
  - (ii) State the **three** main fishing ports in New England.
  - (iii) What factors have favoured the growth of industries in New England?
- (b) (i) How has New England tried to solve the problem of limited local raw materials?
  - (ii) Mention **two** of the traditional industries in New England.
- (c) (i) What were the causes of industrial decline in New England?
  - (ii) Which **two** industries were traditional but have continued to grow?
  - (iii) Name **three** products of new type (modern) industries.

## REGION II: THE RHINELANDS

- 10.
- (a) Draw a sketch map of Switzerland to show the major physical regions.
  - (b) Name the region where each of the following is found:
    - (i) Hanging Valleys.
    - (ii) Moraine dammed lakes.
    - (iii) Sink holes.

- (c) Explain how each of the features in (b) above was formed.
- (d) Describe the main economic activities carried out in each of the regions identified in (a) above.

**11. Study the map of the Rhine Basin and answer questions about it.**

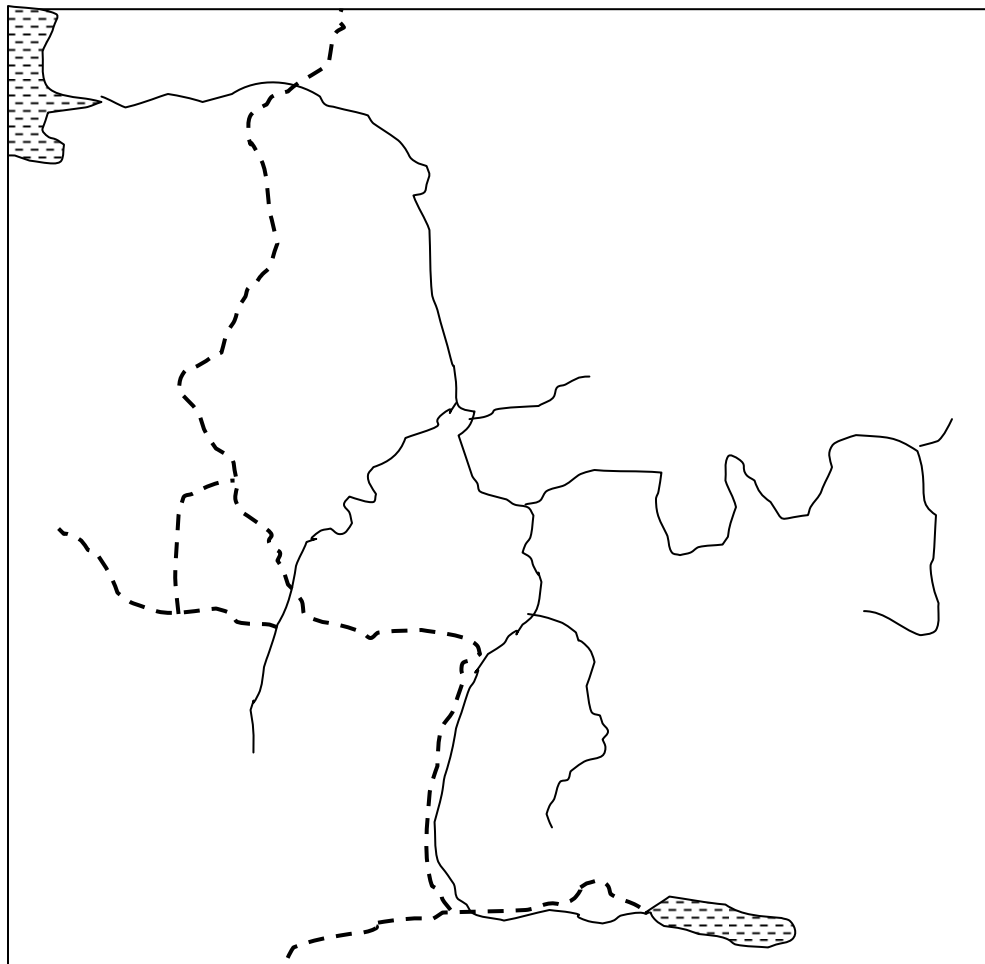

- (a) On the outline map of the Rhine Basin mark and name the following:  
 The Alps, Vosges, Black Forest, two tributaries of the Rhine, the Ruhr industrial region, Rotterdam, Düsseldorf, Ludwigshafen and Basle

(b) All the towns you have marked have important chemical industries.

Choose any three of them and for each explain why the town has developed important chemical industries.

(c) Make a list of six main products of these chemical industries.

**12. Read the passage below and answer the questions which follow.**

“Rotterdam is a very old port. By 1900 it had become the most important port along the North Sea Coast. At the beginning of World War II it ranked third, being surpassed by New York and London.

Finally, in 1962 Rotterdam became the most important port in the world judged in terms of the tonnage of goods handled.

(Adapted from David Hughes and Tom Randle “The Rhine Basin: A Study of Development, page 141).

(a) State:

(i) **Three** exports.

(ii) **Three** imports handled by Rotterdam.

(b) (i) Give **five** reasons to suggest that Rotterdam is an important port.

(ii) What are the factors for the growth of Rotterdam?

(c) (i) State **four** factors which have favoured the development of industries in Rotterdam.

(ii) Mention any **five** of the industries found in Rotterdam.

**E N D**