

Name:.....Stream:.....

ST. HENRY'S COLLEGE KITOVU

END OF TERM I EXAMINATIONS 2004

PHYSICS

TIME: 2 HOURS 15 MINUTES

S.4

INSTRUCTIONS:

- Answer **all** questions in Section **A** and **B**.
- In Section **A**, encircle the correct alternatives **A, B, C or D**. In Section **B**, answers must be given in the spaces provided.

| | | |
|----------------------------------|---|---|
| Acceleration due to gravity, g | = | 10 ms^{-2} . |
| Specific heat capacity of water | = | $4200 \text{ J kg}^{-1} \text{ K}^{-1}$ |
| Density of water | = | 1000 kgm^{-3} |

SECTION A

1. Eggs packed in a soft, shock-absorbing box are placed in a car. When the car suddenly starts or stops moving, the eggs do not crack because:
A. no force acts on them.
B. the force acts on them for only a short time.
C. the force on them is small and acts for a longer time.
D. the force acting on them causes fast change in momentum.
2. A hot air balloon is made from very light material. It displaces 360 kg of air and contains 300m^3 of hydrogen of density 0.3 kgm^{-3} .
The maximum load the balloon can lift is:
A. 90 kg B. 270 kg C. 450 kg D. 360 kg.
3. Which of the following pairs gives a defect and its correction in a simple cell?

| | Defect | Correction |
|----|---------------|-------------------------------|
| A. | Local action | Use Zinc amalgam |
| B. | Polarisation | Dilute the electrolyte |
| C. | Local action | Add oxidizing agent |
| D. | Polarisation | Use concentrated electrolyte. |

4. In the diagram below, a ray of light is incident on a plane mirror at point O.

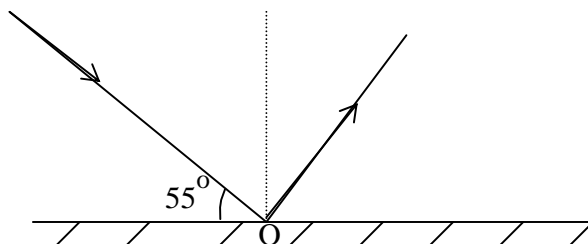

The mirror is rotated through an angle of 30° about an axis at O perpendicular to the paper. The possible angles of incidence are:

- A. 5° and 85° C. 5° and 65°
B. 25° and 65° D. 85° and 25°
5. An echo is produced when sound waves are:
A. bent around corners of object. C. transmitted by an object.
B. deflected back by an object. D. absorbed by an object.
6. A ball thrown vertically upwards returns to the point of projection 12s later. The velocity of projection of the ball is:
A. 120 ms^{-1} C. 30 ms^{-1}
B. 60 ms^{-1} D. 10 ms^{-1}
7. A land breeze occurs when:
A. cool air from land blows towards the sea.
B. warm air blows towards the sea.
C. it is night time.
D. warm air blows towards land.
8. The gold-leaf of a charged electroscope with a needle placed on its cap is observed to collapse slowly. This is due to:
A. electrons escaping through the sharp point thus discharging the electroscope.
B. electrons entering the electroscope through the sharp point and discharging the electroscope.
C. the sharp point accumulating charges and ionizing molecules which are attracted and neutralizing the electroscope.
D. Positive charge attracting electrons from the surrounding air to the sharp point and neutralizing them.
9. The useful power of a machine which is 80% efficient is 1kW. Calculate the energy input if the machine operates for 20 minutes.
A. $9.6 \times 10^5 \text{ J}$ C. $1.5 \times 10^6 \text{ J}$
B. $1.25 \times 10^3 \text{ J}$ D. 400 J

10.

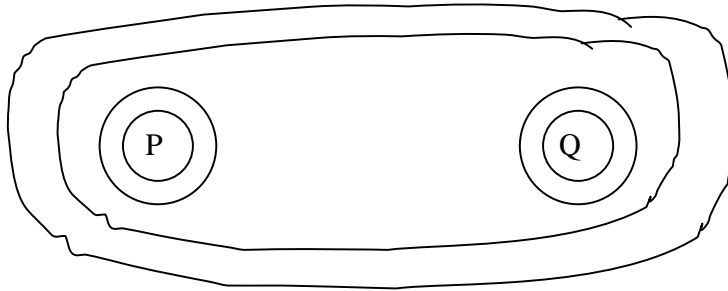

The figure above shows the magnetic field pattern around two wires P and Q, carrying current perpendicular to the plane of the paper. Which of the following statement is true?

- A. Current in P is flowing into the page while that of Q is flowing out of the page.
 - B. Both currents in P and Q are flowing into the page.
 - C. Both currents in P and Q are flowing out of the page.
 - D. Current in Q is flowing into the page and that in P is flowing out of the page.
11. In order to make a mercury thermometer which will measure small changes in temperature accurately, then we should:
- A. put the degree markings closer together.
 - B. Put the degree marking farther apart.
 - C. Decrease the volume of the mercury bulb.
 - D. Decrease the diameter of the capillary tube.
12. A rectangular solid body of mass 500 g has dimensions of 2 cm by 10 cm by 30 cm. If the body is placed on a flat surface, what is the maximum pressure it can exert on the surface?
- A. 250Nm^{-2} B. 2500Nm^{-2} C. 167Nm^{-2} D. 833Nm^{-2}
13. A 100 cm uniform rod of weight 5N has a weight of 10N attached at one end. The center of gravity of the stick is:
- A. 33.3 cm from the weight. C. 66.7 cm from the weight
- B. 16.7 cm from the weight. D. 30.0 cm from the center of the rod.
14. In order to move in a circular path at a uniform speed, a body required centripetal force. The direction of this force is:
- A. towards the center of the circle.
 - B. away from the center of the circle.
 - C. tangential to the circular path.
 - D. along the circumference of the circle.
15. An a.c input voltage of 250V is connected to a transformer with 1000 turns. Calculate the number of turns of the secondary coil if an output of 15V is required.
- A. $\frac{1000}{(250 + 15)}$ B. $\frac{1000}{(250 - 15)}$ C. $\frac{1000 \times 15}{250}$ D. $\frac{1000 \times 250}{15}$

16. Which of the following best describes a magnetic domain?
- A region of zero resistance to the flow of electrons.
 - A region of infinite resistance to the spinning electrons.
 - A region where the magnetic field of atoms are aligned up in a specific direction.
 - A region where the some atoms are magnetic while some are non-magnetic.
17. When a hole in a pin-hole camera is enlarged, the image becomes:
- brighter and bigger.
 - blurred but brighter.
 - blurred and inverted.
 - blurred but faint.
18. Which one of the following correctly describes the effect of impurity on the boiling and freezing point of water?
- It raises the boiling point and raises the freezing point.
 - It raises the boiling point and has no effect on the freezing point.
 - It raises the boiling point and lowers the freezing point.
 - It lowers the boiling point and raises the freezing point.
19. 150 g of water at 100°C is mixed with 50g of water at 20°C . Assuming no heat is lost to the surrounding, the temperature of the mixture is:
- 50°C
 - 60°C
 - 70°C
 - 80°C
20. Wire PQ is a part of an electric circuit and is between the poles of a magnet. The arrow indicates the direction of the electron flow.

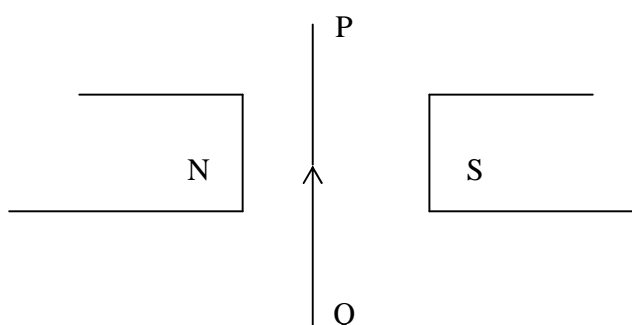

- In which direction does PQ experience a force?
- Out of page.
 - Towards South Pole.
 - Into the Page.
 - Towards North Pole.
21. When a mercury-in-glass thermometer is immersed in a melting ice and then in steam, the lengths of the mercury thread in the stem are 3 cm and 18 cm respectively. The temperature at which the length of the mercury thread would be 12 cm is:
- 30°C
 - 40°C
 - 50°C
 - 60°C
22. Some air in a flask is heated from 20°C to 40°C . What effect does this have on the average speed of the molecules and the pressure they exert?
- Average speed doubled, pressure increased a little.
 - Average speed increased a little, pressure increased a little.
 - Average speed increased a little, pressure doubled.
 - Average speed the same, pressure increased a little.

23. A ship steams from fresh water in river to the ocean. Which of the following is true?
 A. The density of water increases and the ship sinks a little.
 B. The density of water increases and the ship floats a little higher in ocean.
 C. The density of water decreases and the ship sinks a little.
 D. The density of water decreases and the ship floats a little higher in ocean.
24. When a mass of 10g is hung on a spring, the length of the spring is 9 cm. When a further 5g are added, the length increases to 11 cm. What is the unstretched length of the spring?
 A. 2 cm
 B. 5 cm
 C. 7 cm
 D. 8 cm
25. When a given mass is changing from liquid state to the gaseous state, there is no change in its:
 (i) volume (ii) temperature (iii) mass
 A. (i), (ii) and (iii)
 B. (i) and (ii)
 C. (ii) and (iii)
 D. (i)
26. In which of the following devices is kinetic energy converted electrical energy?
 A. An accumulator.
 B. A dynamo.
 C. Electric motor.
 D. A combustion engine.
27. An air bubble is introduced at the bottom of a jar containing mercury. Which one of the following explains what will happen to the bubble? It will
 A. be pressed by the mercury column above and will burst.
 B. rise to the surface of the mercury while decreasing in size.
 C. rise to the surface of mercury while increasing in size.
 D. remain in constant motion within mercury.
28. A liquid X of volume 0.40 m^3 and density 900 kg m^{-3} is mixed with liquid Y of volume 0.35 m^3 and density of 800 kg m^{-3} . The density of the mixture is:
 A. 850 kg m^{-3}
 B. 853 kg m^{-3}
 C. 1700 kg m^{-3}
 D. 840 kg m^{-3}
29. A parallel beam of light is produced by reflection from a concave mirror when a point source of light is:
 A. at the center of curvature of the mirror.
 B. at the pole of the mirror.
 C. between the pole and the principal focus.
 D. at the principal focus of the mirror.
30. An object of mass 2 kg moving at 5 ms^{-1} collides with another object of mass 3 kg which is at rest. Find the velocity of the two bodies if they stick together after collision.
 A. 1.0 ms^{-1}
 B. 2.0 ms^{-1}
 C. 2.5 ms^{-1}
 D. 5.0 ms^{-1}

31. When a saturated vapour is compressed,
- more liquid evaporates to keep pressure constant.
 - The vapour becomes unsaturated.
 - Vapours condenses keeping pressure constant.
 - The amount of vapour remains constant and pressure increases.

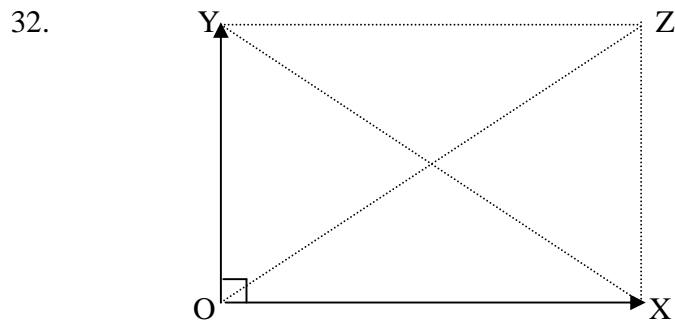

The figure above shows two forces acting at a point O represented in magnitude and direction by OX and OY. The third force required to maintain equilibrium is represented in magnitude and direction by:

- OZ
 - XY
 - ZO
 - YX
33. In testing for the polarity of a magnet, the following were written down by experimenter.
- Attraction only indicates two unlike poles.
 - Repulsion will indicate two like poles.
 - Attraction may indicate a pole and an unmagnetised ferromagnetic material.

Which of these are correct?

- (i) and (ii)
 - (ii) and (iii)
 - (i) and (iii)
 - (i), (ii) and (iii)
34. A ray of light is incidence on a glass block at an angle of 40° and he angle of refraction is 21° . Find the critical angle of the glass.
- 41.8°
 - 40.0°
 - 33.8°
 - 35.0°

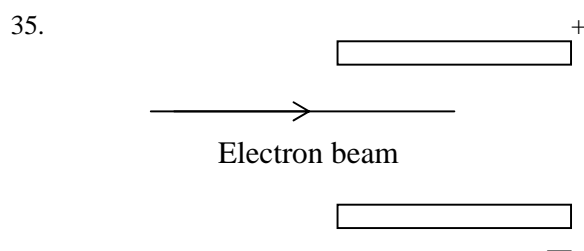

2.

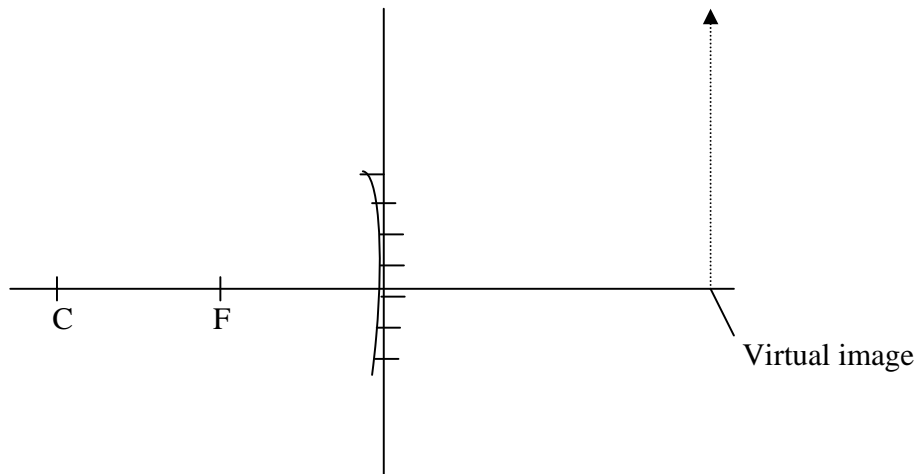

An object is placed in front of a concave mirror of focal length 10 cm and its image is formed 20 cm behind the mirror as shown above. On the diagrams, draw rays to find

(a) object distance

.....

(b) object height if the height of image is 24 cm.

.....
.....

3. (a) State Charle's law

.....
.....
.....

(b) What do you understand by S.T.P.?

.....
.....
.....

(c) A fixed mass of a gas have volume of 120 cm^3 at 27°C and pressure 750 mmHg .
What is its volume at S.T.P.?

.....

4. (a) State two factors which affects rate of evaporation.

(i).....
.....

(ii).....
.....

(b) What are the functions of the following in a refrigerator

(i) Compressor?
.....
.....

(ii) Cooling pins?
.....
.....

5. (a) Explain, with the aid of a sketch diagram, how a notch weakens a beam of a brittle materials.

(b) State two ways in which concrete may be made stronger.

.....
.....
.....
.....

6. (a) State the conditions for total internal reflection to occur.

.....
.....
.....
.....

(b) A ray of light is travelling from glass of refractive index $\frac{3}{2}$ to water of refractive index $\frac{4}{3}$. Calculate the critical angle of the glass.

.....

7.

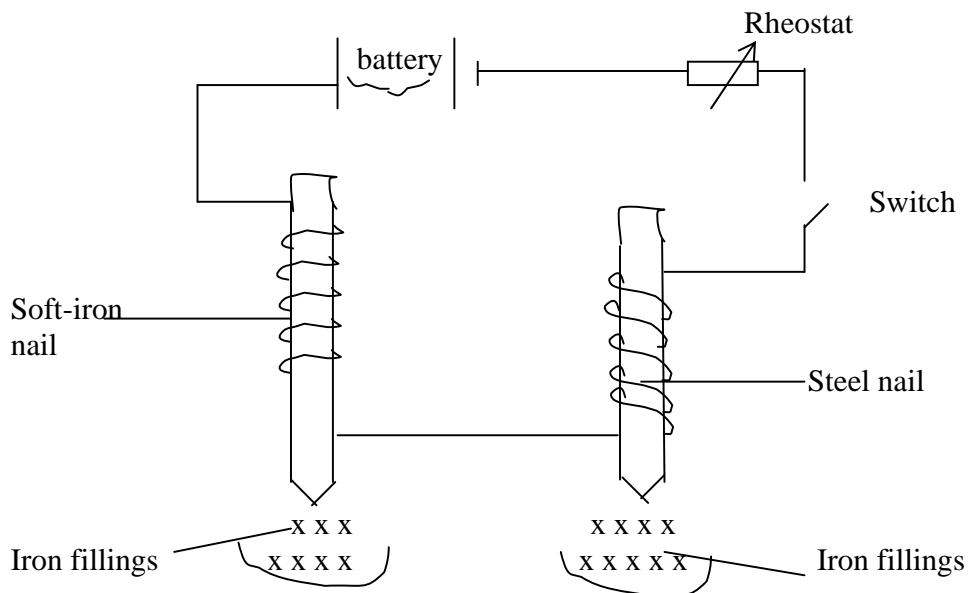

Study the diagram above and answer the question below.

- (a) What would be observed when the switch is
 (i) closed?

.....

- (ii) opened after closing?

.....

- (b) State what would happen if the switch was closed and the rheostat adjusted to give a larger current.

.....

8. A solid of volume 2m^3 floats in water with $\frac{3}{4}$ of its volume submerged.

- (a) Find the mass of the solid.

.....

.....
.....
.....

(b) If the same solid floats in another liquid with $\frac{4}{5}$ of its volume submerged, what is the density of the liquid?

.....
.....
.....
.....

9.

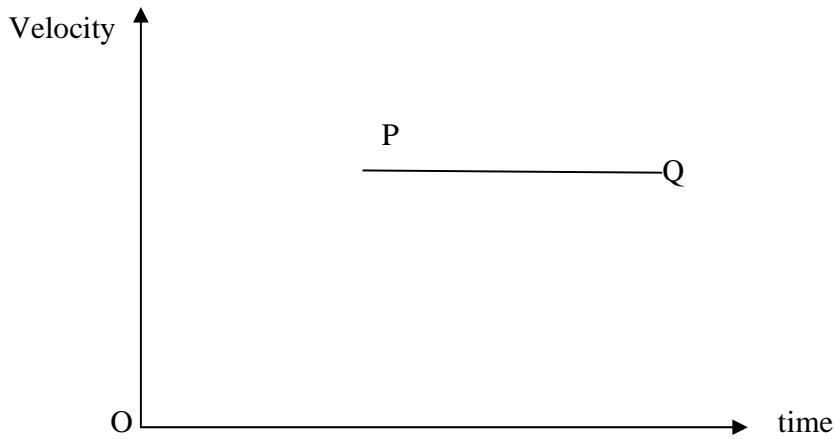

The velocity-time graph represents the motion of a small sphere dropped centrally down a tall column of a liquid.

(a) State the forces which act on the sphere.

.....
.....
.....

(b) What happens to the sphere between P and Q?

.....
.....
.....

P.T.O.

10.

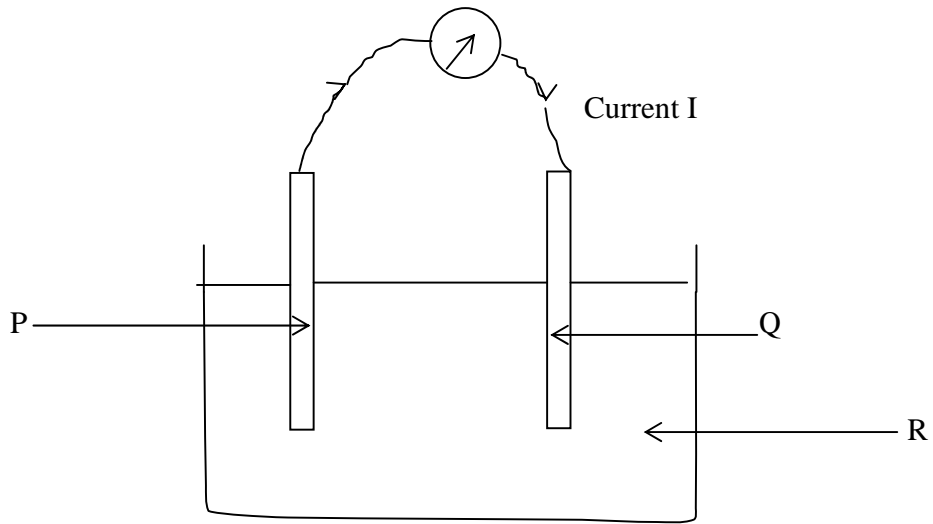

The figure above shows essential parts of a simple cell.

(a) Name the parts labeled:

P:.....

Q:.....

R:.....

(b) Why does the current through the ammeter eventually stops?

.....

.....

END