

ST. HENRY'S COLLEGE KITOVU
END OF TERM II EXAMINATIONS – 2004
PHYSICS

Time: 2 Hours.

S.5 B/M

INSTRUCTIONS:

- (i) Attempt all questions.
- (ii) Assume the following constants where necessary
Permittivity of free space $\epsilon_0 = 8.85 \times 10^{-12} \text{ Fm}^{-1}$
The constant $\frac{1}{4\pi\epsilon_0} = 9 \times 10^9 \text{ F}^{-1}\text{m}$

1. (a) Show that when a ray of light passes through different media separated by plane boundaries, then
$$n \sin i = \text{constant}$$
where n is the absolute refractive index of a medium and i is the angle made by the ray with the normal in the medium. (4)
- (b) A liquid is placed in a concave mirror to a depth of 2cm. An object held above the liquid coincides with its own image when it is 45.5cm from the pole of the mirror. If the radius of curvature of the mirror is 60cm, calculate the refractive index of the liquid. (4)
- (c) (i) What is the centre of curvature of a convex mirror? (1)
(ii) With reference to a concave mirror explain what is meant by spherical aberration. (3)
- (d) Explain the apparent shape of the bottom of a pool of water to an observer at the bank of the pool. (4)
- (e) A fish is 3m below the surface of a pond and 2.5m from the bank. A man 2m tall stands 4m from the edge of the pond. Assuming the sides of the pond are vertical. Calculate the distance the man should move towards the edge of the pond so that he is just seen by the fish. Take the refractive index of water to be 1.33. (4)
2. (a) State Snell's law
- (b) (i) Explain the terms 'critical angle' and total internal reflection' (4)
(ii) State two applications of total internal reflection. (2)
- (c) Describe a critical angle method for the determination of the refractive index of water. Illustrate your answer with a diagram showing the optical arrangement for the method and explain how the result is obtained from the observation. (6)
- (d) Calculate the critical angle for a glass-water interface if a ray of light which is incident in water on the glass surface is deviated through 4.6° when its angle of incidence is 30° . (4)
(Take the refractive index of water $n_w = 1.33$)

- (e) With the aid of a diagram explain why light from the sun can be received before the sun rises above the horizon. (3)

3. (a) Deduce an expression for the energy stored in a capacitor charged to a p.d V . (5)
- (b) A $10.0 \mu\text{F}$ capacitor is charged to 500V , disconnected from the voltage supply, and then connected in parallel with an uncharged $40 \mu\text{F}$ capacitor. Calculate the total energy stored in both capacitors before and after connection. (4)
Explain how conservation of energy applies to this process. (1)
- (c) You are provided with a standard capacitor and a capacitor of unknown capacitance. Describe how you would determine the unknown capacitance. (4)

(d)

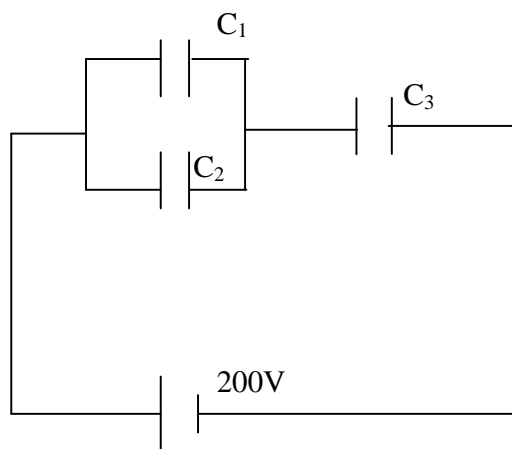

In the figure above, C_1 , C_2 and C_3 are capacitors of capacitance $2 \mu\text{F}$, $4 \mu\text{F}$ and $3 \mu\text{F}$ respectively

Calculate:

- (i) The energy stored in all the capacitors when fully charged. (3)
- (ii) The energy in charge stored in the capacitors if the space between the plates of C_3 had been filled with an insulator of dielectric constant 3. (3)

4. (a) Define resistivity and temperature coefficient of resistance (t.c.r. α) of a material of a wire. (2)
- (b) A metal wire 100cm long and $1 \times 10^{-6} \text{m}^2$ cross-section has resistance of 0.20Ω at 0°C . Calculate the resistivity of the metal at 500°C given that its temperature coefficient of resistance is $6.2 \times 10^{-3} \text{K}^{-1}$ (Neglect any thermal expansion). (5)
- (c) The temperature coefficient of resistance of the material of a wire is $5.0 \times 10^{-4} \text{K}^{-1}$. Find the length of the wire of diameter 1mm and resistivity $1 \times 10^{-6} \Omega \text{m}$ at 25°C needed to make a coil of resistance 6.0Ω at 95°C . (5)
- (d) (i) Obtain from first principles, an expression for the heat in joules dissipated in a conductor of resistance R ohms, when a p.d v volts is maintained across for a time t seconds. (3)

- (ii) An electric heating element is made of a nichrome ribbon of width 1mm and thickness 0.05mm. It dissipates 450W when connected to 250 mains. Calculate the length of ribbon.
(Resistivity of nichrome is $1.1 \times 10^{-6} \Omega \text{ m}$). (5)

END